

Spatial R-C-C-R Mechanism for a Single DOF Gripper

Rajeev Lochana C.G*

Mechanical Engineering Department

Indian Institute of Technology Delhi, New Delhi, India

* Email: rajeev@ar-cad.com

Abstract

The paper presents a novel end-effector or gripper which can be used in various automation processes including “Pick and Place” operation by a robotic arm. The gripper is made up of a spatial arrangement of Revolute-Cylindrical-Cylindrical-Revolute (R-C-C-R) joints, and by its virtue; it has a single degree of freedom. Since the gripper fingers have synchronous motion and grasp the object in more than one plane in a “tip” grasping configuration, it could be used to grasp certain shaped objects in 3D and hence can be used more effectively and efficiently to pick and place them. Further, various shapes for the gripper fingers have been explored to use it as external, internal and dual purpose gripper, and also to be used to grasp objects of different sizes.

Keywords: Spatial R-C-C-R, Single DOF gripper, Robotic end-effector, Grasp stability

1 Introduction

Robotic Automation is one field which is being evolved and developed rapidly over the years and one of its critical elements is the end-effector. Basic grasping end-effectors are also referred to as grippers. The design of the gripper depends on the robot on which it is being implemented, objects to be grasped, tasks to be performed and the work environment, apart from various other factors. Typically a gripper consists of one or more moving links or jaws by adjusting which objects can be grasped and released, and their movement is controlled by a motor or actuator. It is desirable for the gripper to have a single degree-of-freedom (DOF) to reduce the weight of the motors. But this puts a limitation on the dexterity and the extent to which the gripper can be used, making its application very specific.

It has been found that [2] majority of the single DOF grippers are planar in nature, such as

- a) Parallel Axis/ Linear Motion Jaws
- b) Pivoting/ Rotary Action Jaws
- c) Four-Bar Linkage Jaws

Out of the single DOF spatial grippers, the most common one is “Multiple Jaw/ Chuck Style Jaws”, which operates similar to a machine tool multi-jaw chuck. Six basic grasping patterns of the human hands have been identified [3] to be (1) spherical, (2) cylindrical, (3) hook, (4) lateral (5) palmar and (6) tip. Spatial grippers are preferred over planar grippers for better grasping stability. It is found [2] that the grasp stability improves when the gripper jaws or fingers enclose around the center of gravity of the object and also with the number of contact points between the gripper fingers and grasped object.

2 Novel Spatial Gripper

The gripper presented in this paper in its basic setup (Figure 1) consists of a polygonal hub; each face on its side is connected with a gripper finger, through a revolute joint whose axis is parallel to the corresponding polygonal edge. The fingers have holes drilled at certain distance from the revolute joint and their axes are parallel to axes of corresponding revolute joint. Bent rigid rods with bend angle equal to the interior angle of the polygon are inserted inside the holes of adjacent fingers. Each side of the bent rod forms a cylindrical joint with the corresponding finger. When all the bent rods are inserted, the fingers form a closed loop spatial R-C-C-R mechanism with a single DOF.

It is found that each R-C-C-R joint is a constant velocity coupling with unit velocity ratio [1] and this makes it useful in applications where unit velocity ratio is strictly required. In the proposed robotic gripper, rotational input is given to the crank of the four bar mechanism at the top of the hub, which oscillates one of the fingers, which in turn opens (Figure 1) and closes (Figure 2) the other fingers of the gripper. The movement of the fingers is synchronous and the extent of their movement can be controlled by the rotation of the crank of the four bar mechanism (Figure 3), and thus it can be used to grasp and release objects and can be used in a pick and place robotic system.

2.1 Features of Novel Gripper

The novel gripper in its conceptual stage satisfies the conditions for better grasp stability. Some of the features are:

- a) The gripper can be operated by using a single input as it has a single DOF. Due to the synchronous motion of the fingers in more than one plane, they grasp the object in a “tip” type of grasping configuration (Figure 4)
- b) It can enclose the center of gravity of the object around its fingers, thus improving grasp stability.
- c) It has more contact points with the grasped object and the contact forces between the gripper fingers and object are also in more than one plane and hence improving grasp stability.
- d) The gripper can be thought of as a hybrid of “Pivoting/ Rotary Action Jaws” (Figure 5) and “Multiple Jaw Chuck Style Jaws” (Figure 6).
- e) The number of gripper fingers can vary from 3 to any number, depending on the shape of the object to be grasped. The number of sides of polygonal hub and the angle of bent rods need to be changed accordingly.
- f) The shape and profile of the gripper fingers can be made in such a way that it can be used to grasp objects of different dimensions and also can be used as an external, internal and dual purpose gripper, as explained later in this paper.

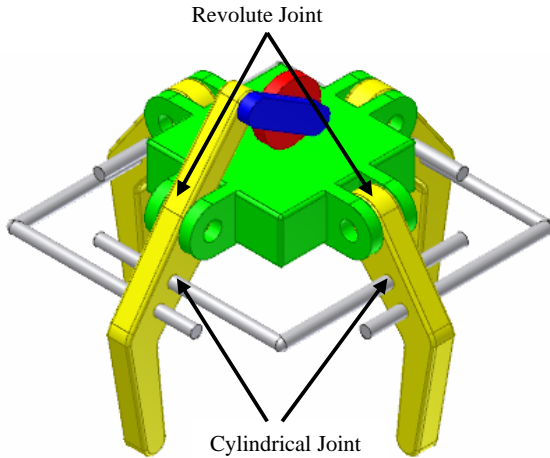

Figure 1: Gripper in open configuration

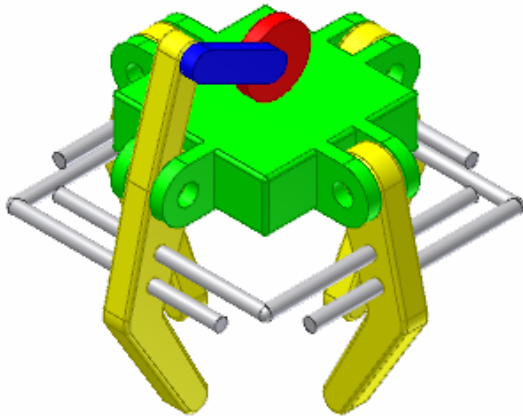

Figure 2: Gripper in closed configuration

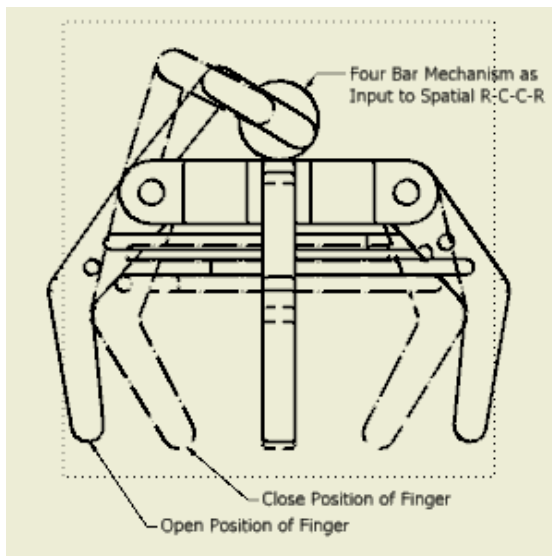

Figure 3: Four bar mechanism as an input to R-C-C-R mechanism

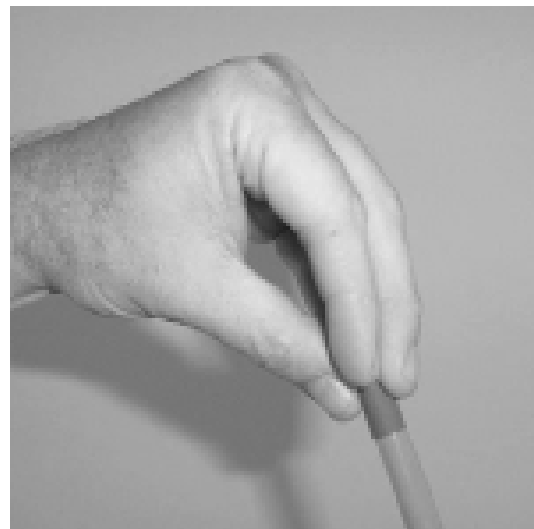

Figure 4: Tip grasp type for human hand.

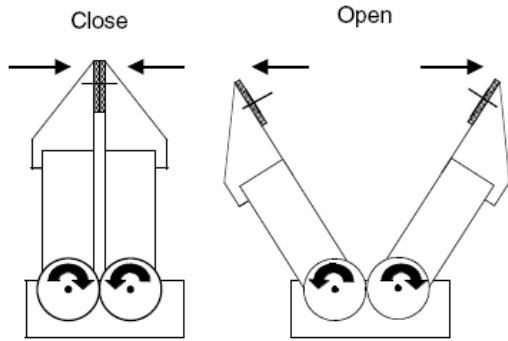

Figure 5: Rotating axes / pivoting jaws

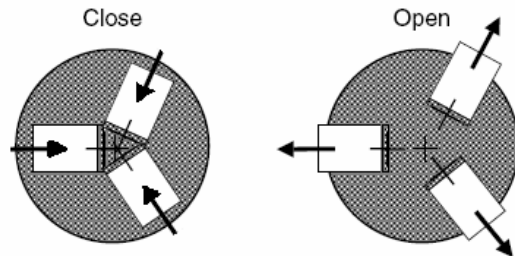

Figure 6: Multiple jaw chuck style jaws.

3 Variants of the Gripper

Several variants of the proposed gripper have been explored by modeling and simulation using CAD software, Autodesk Inventor. By changing the profile of the fingers and also the direction in which the input motion is given, the gripper can be used as an external gripper, an internal gripper or as a dual purpose gripper. The profile of the fingers can be made to grasp objects of different dimensions.

3.1 External Gripper

The contact surfaces are on the inner side of grasping fingers and hence can be used to grasp solid objects externally as shown in Figure 7.

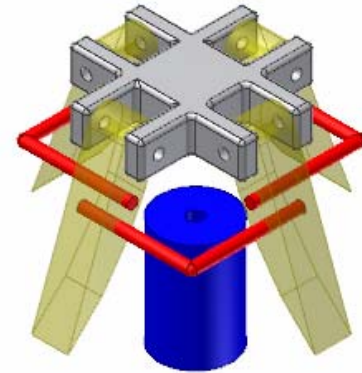

Figure 7: External gripper grasping a solid object.

3.2 Internal Gripper

The contact surfaces are on the outer side of grasping fingers and hence can be used to grasp hollow objects internally as shown in Figure 8.

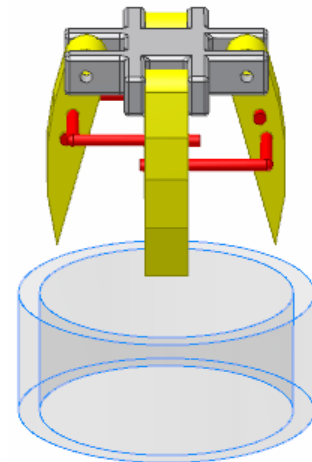

Figure 8: Internal gripper grasping a hollow object.

3.3 Dual Purpose Gripper

The contact surfaces are both on the outer and inner sides of grasping fingers as shown in Figure 9 and hence can be used as both external and internal gripper, without dismantling the gripper sub assembly.

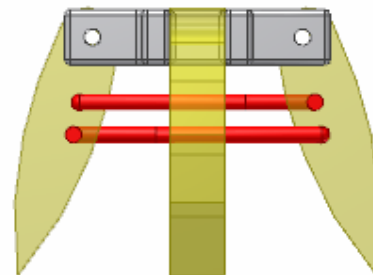

Figure 9: Dual purpose gripper.

3.4 Dexterous Gripper Fingers

The gripper finger's contact surface can be made to have multiple contact surfaces as shown in Figure 10, such that they are inclined at certain angle with respect to the adjoining surface. By the virtue of its shape, the fingers can now grasp objects of different dimensions, as illustrated in Figure 11, 12 and 13, though some adjustments need to be done with respect to centering of the "Center of Gravity" of the object. The number of contact surfaces and their inclination angle can be set as per the dimensions of the objects to be grasped

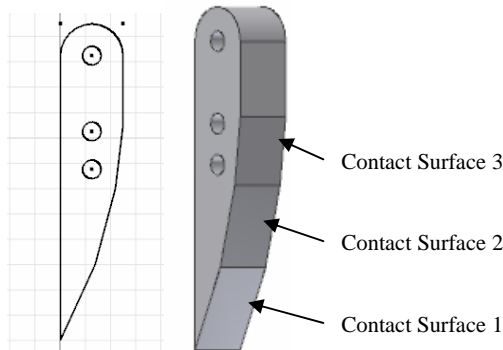

Figure 10: Profile of gripper fingers.

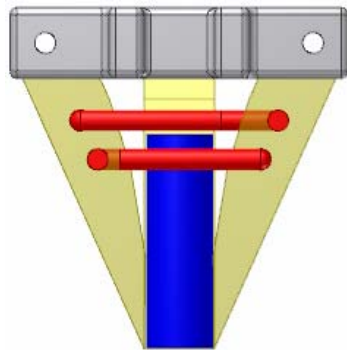

Figure 11: Fingers grasping small sized object.

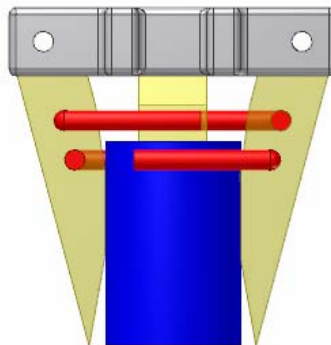

Figure 12: Fingers grasping mid sized object.

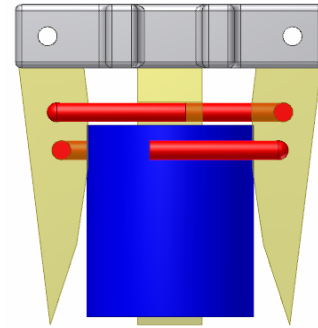

Figure 13: Fingers grasping big sized object.

4 Future Scope

The concepts developed so far have been modeled and simulated in Autodesk Inventor. The following tasks need to be done

- Dimensional synthesis of the gripper mechanism for all possible variants
- Static load analysis for grasping an object
- Dynamic load analysis by considering the effects of forces due to the action of gravity and inertia when the gripper moves with a grasped object.
- A Rapid Prototype model of the gripper to verify its functionality.

5 Conclusions

This paper presents concepts for a novel gripper with single DOF, which is made up of a spatial arrangement of Revolute-Cylindrical-Cylindrical-Revolute (R-C-C-R) joints. The gripper needs a single input motion and the movement of the grasping fingers is synchronous in more than a plane, which improves the grasp stability of the gripper. It can be used as an end-effector, in a robotic manipulator to perform common "Pick and Place" operations. By making certain changes to the fingers profile, it can be used for external, internal or dual purpose grasping of objects. The concept is further extended by making the gripper finger's profile to have multiple contact surfaces to grasp objects of different dimensions.

Acknowledgment

I thank Prof. Dibakar Sen, Mechanical Engineering Dept, Indian Institute of Science, Bangalore, India for helping in the initial stages of conceptualization of spatial R-C-C-R mechanisms and its applications in Deployable Space Antennae. I also thank Prof. S.K Saha, Mechanical Engineering Dept, Indian Institute of Technology Delhi, New Delhi, India for letting me use

the Mechatronics Lab of IIT Delhi, for his guidance, and also for reviewing this paper.

References

[1] Rajeev Lochana C.G, Dibakar Sen, "Studies on a Novel Constant Velocity Mechanism and Exploring its Use in Deployable Structures," in 5th National Seminar on Aerospace and Related Mechanisms (ARMS 2005), 2005

[2] Thomas R Kurfess, "Robotics and Automation Handbook," *Design of Robotic End Effectors*, CRC Press, 2005.

[3] Taylor, C.L. and Schwarz, R.J., "The Anatomy and Mechanics of the Human Hand: Artificial Limbs", Vol. 2, page 22–35, 1955.